

high performance. advanced scan control.

RTC6 control boards enable smart and flexible control of scan systems, lasers and peripheral devices in real time.

Key Features:

- SCANahead control
- UltraFastPixelMode (up to 3.2 MHz)
- Enlarged list memory
- Standalone functionality for RTC6 Ethernet

Based on the field-proven RTC5, the RTC6 control board delivers new functionalities to tackle complex control tasks. Examples are improved speed and position-dependent laser control and the synchronization of the usually faster x/y scan axes with the slower z-axis. This allows more precise results in 3D processing.

Complete incorporation of all RTC5 functions ensures quick, easy migration to the new RTC6 board.

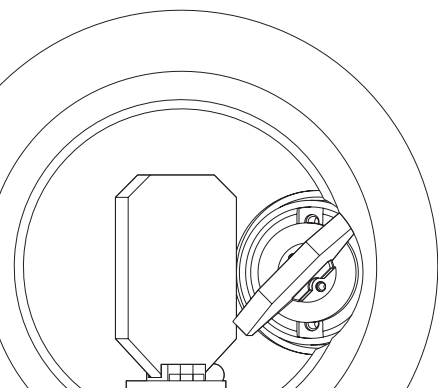

System Integration

- PCIe bus interface, Ethernet interface
- Up to 255 RTC6 control boards per PC
- Master/slave synchronization
- Drivers for Windows 10/8/7 (32-bit and 64-bit)
- Multi threading, multi processing

Scan System Control

- SL2-100 transfer protocol (control of scan systems with XY2-100 transfer protocol via an optional converter)
- 20-bit positioning resolution
- Virtual processing field (29 bit)
- 10 µs output period
- Synchronization of the 10 µs RTC clock to an external laser clock signal
- Galvanically isolated signals
- Tuning selection
- Vector and jump mode, tuning auto-switching
- Scan-system diagnosis
- Reading back actual-position values

Laser Control

- 15-pin D-Sub connector
- Laser signals with 15 ns resolution and 20 mA output current
- Various laser modes for controlling all typical lasers
- Bitmap mode with pixel frequencies up to 3.2 MHz, 0-100% laser pulse width (15 ns resolution), additional digital-ports as output ports
- RS232 interface
- Speed- and position-dependent laser control

Control of Peripheral Equipment

- 16-bit digital output and input
- 8-bit digital output
- 2-bit digital output and input
- 12-bit analog output (0...10 V)
- McBSP interface
- Stepper motor signals

Command Management

- Configurable list buffers with more than 8 million list positions, protected memory area definable
- Lists and subroutines
- "Short" list commands for changing (laser) output signals without interrupting polygonal traversal or laser switch-off

- Download verification
- Enhanced list and list execution status
- Definable and selectable character sets
- Marking of dates, times and serial numbers
- Marking of circles and ellipses
- Sky writing
- Conditional execution of all list commands possible

Options

- SCANAhead
- Control of 3-axis scan systems
- Processing-on-the-fly functionality for objects in motion (two encoder inputs with 32-bit counter, up to 8 objects between trigger and marking position, etc.)
- Simultaneous control of two scan systems
- Customer-specific software extensions possible
- UltraFastPixelMode (UFPM) for frequencies higher than 800 kHz
- Spot Distance Control (SDC) (only with SCANAhead and with special pulse-on-demand lasers)

Accessories

- **laserDESK**
laser processing software

Comparison of RTC6 – RTC5

	RTC6	RTC5
PC Interface	PCIe, Ethernet	PCI, PCIe
SCANAhead control	for controlling excelliSCAN (optional)	no
Synchronization (scan system control)	10 µs RTC clock synchronization	output synchronization
Pixel frequency (bitmap mode)	800 kHz maximum	308 kHz maximum
UltraFastPixelMode (UFPM)	3.2 MHz maximum (optional)	no
List memory	8 million list positions	1 million list positions
3D correction files	up to eight 3D correction files	up to two 3D correction files
Output period	10 µs	10 µs
Transfer protocol	SL2-100	SL2-100
Software drivers	drivers for Windows 10/8/7 (32-Bit and 64-Bit)	drivers for Windows 10/8/7 (32-Bit and 64-Bit) Vista/XP (ab SP2)

07/2021 Information is subject to change without notice. - Product photos are non-binding and may show customized features.