

the premium scanning standard

excelliSCAN scan heads set new standards for the most demanding laser scanning requirements. These high performance 2D scan systems offer highly dynamic and accurate positioning of the laser beam in the working plane.

With its high-end design, the excelliSCAN achieves an unprecedented level of performance in terms of dynamics and precision, resulting in a significant increase in productivity and process accuracy.

Key features

- Innovative housing concept with improved thermal management, improved tightness (IP66) and robustness
- SCANAhead control: full utilization of scanner dynamics for higher throughput and precision
- Ready for SCANmotionControl

Typical applications

- Micromachining
- Additive manufacturing (3D printing)
- Laser cutting

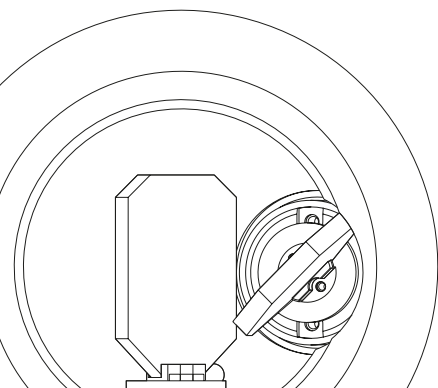

Advantages

SCANahead Control

excelliSCAN systems are equipped with SCANahead control, which offers the following advantages:

- Full utilization of galvo dynamics for increased throughput
- No tracking error, even at high speeds
- Fast marking of circles without necking effects

dynAXIS_{se} Galvanometer Scanner

The excelliSCAN is based on the latest generation galvanometer scanner technology, enabling excellent contour fidelity even for demanding scan jobs:

- Digital galvanometer scanners with 20-bit encoder technology for highest positioning accuracy and long-term stability
- Best linearity and minimum position noise ensure highest positioning accuracy

Innovative Housing Concept

In addition to the modern design, the mechanical concept of the excelliSCAN is characterized as follows:

- Robust and tight shell construction (IP66)
- Improved thermal management for best long-term stability
- Separation of optics and electronics
- Efficient water cooling for galvanometer scanners and electronics for highest stability
- Mirror air cooling enables the use of high power lasers

Integration and Control

System Integration

The excelliSCAN can be easily integrated into the machine concept:

- Compact construction with mounting holes on the beam entrance side and beam exit side
- Fast commissioning due to universal tuning and automatically set scanner and laser delays
- Positioning of the electrical connections can be flexibly changed between the beam entrance side or opposite the beam exit side

Variants

The excelliSCAN is available in three apertures:

- 14 mm
- 20 mm
- 30 mm

The 20 and 30 mm variants come with a standard interlock protection function. Temperature sensors for the mirrors and the galvo mount are optionally available.

Control with RTC6

excelliSCAN scan heads are controlled by the powerful RTC6 control board, which is characterized by the following features:

- Powerful DSP, FPGA, and expanded memory
- New Spot Distance Control (SDC) function allows precise laser processing even during acceleration and deceleration phases when used with pulse-on-demand lasers

SCANmotionControl – the innovative trajectory planning software

More degrees of freedom for laser process control

SCANmotionControl makes it easy to control laser and scan system: You specify the machining patterns and process parameters – SCANmotionControl does the rest! The software calculates optimum trajectories for your desired processing result, taking into account the physical limits of the scan system.

You define the tolerable rounding of corners, and set the limits for the processing speed and the maximum laser power. SCANmotionControl ensures optimum results with minimum laser-off times.

More information about SCANmotionControl:



Your benefits:

- Simple job planning and simulation: 'What you see is what you get'
- Shortest process time through optimal use of scanner dynamics and laser power
- Highest precision and exact laser control by trajectory planning

SCANahead Principle of operation

With SCANahead control, the excelliSCAN always reaches the set scan speed using the maximum acceleration of the galvos (i.e. in the minimum acceleration time t_a). In contrast to scanners using conventional tracking error t_s based control algorithms, which have a constant acceleration time regardless of the target speed, the excelliSCAN requires suitably generated control values.

The RTC6 with SCANahead functionality, generates control values for the excelliSCAN with automatically determined delays. Limiting the acceleration of the target path to the maximum acceleration of the scanner axes in the scan head (blue line) ensures that the dynamic potential of the galvos is fully utilized. The calculation is performed in real time – the execution of the movement is accordingly offset by the preview time t_p .

Conventional control

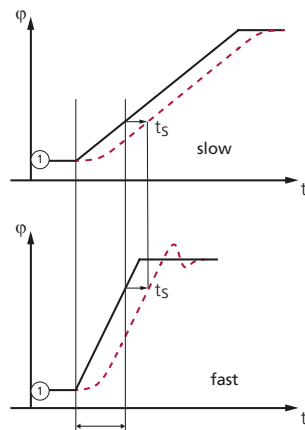

SCANahead control

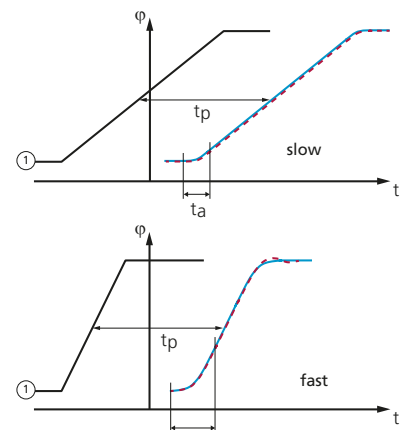

① = RTC6 control values
 blue = Set trajectory
 red = Actual trajectory

t_s = Tracking error
 t_a = Acceleration time
 t_p = Preview time

Application Advantages

- **Increase in productivity** due to significantly shorter acceleration phases
- **Shortened process time** with unchanged process parameters
- **High contour fidelity and long-term stability** with digital encoder technology – even for demanding scan jobs
- **Maximum ease of use** thanks to universal tuning and with automated delay setting

More information about SCANahead in the video:



Example 3D printing: Higher productivity and improved accuracy

Up to now, an increase in productivity in additive manufacturing could primarily be achieved by using multi-head systems or higher laser powers. Additional potential is offered by the use of modern control technologies such as SCANahead control from SCANLAB.

In additive manufacturing, two-dimensional structures are typically realized by bidirectional hatching. A large part of the process time in scan systems with conventional control is required for the turnaround times for acceleration and deceleration processes.

Scan systems with SCANahead control significantly reduce these turnaround times and therefore contribute to a significant increase in productivity.

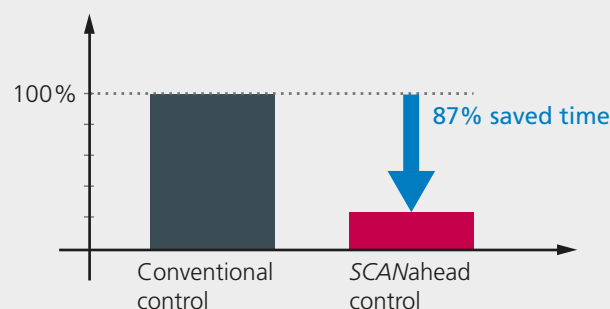
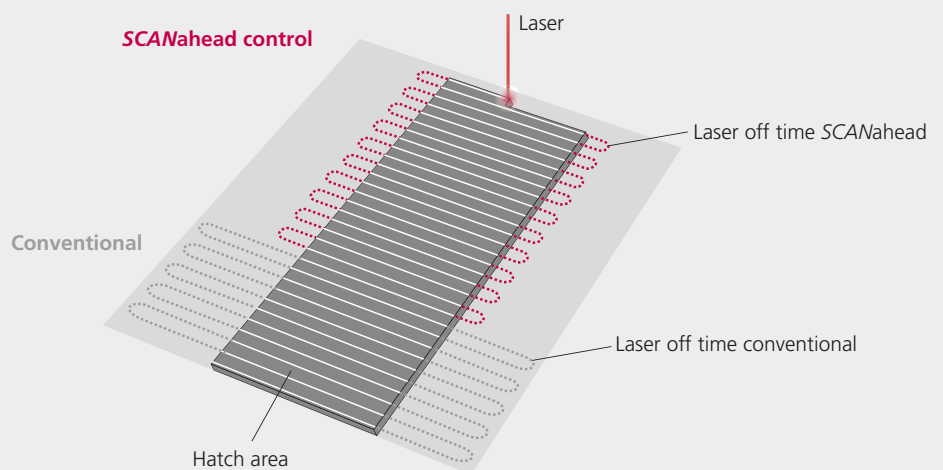

Reduced acceleration time with SCANahead control
 (Simulation results based on system with 20 mm aperture and $f = 500$ mm)

SCANahead Control Compared to Conventional Control

| | Conventional Control | SCANahead Control |
|--|---|--|
| Dynamics | <ul style="list-style-type: none"> Acceleration time t_a is constant Dynamic potential of the galvanometer scanner not used efficiently at all times | <ul style="list-style-type: none"> Scanner axis acceleration always at maximum Fully utilized galvo dynamics |
| Tracking error [t_s] | <ul style="list-style-type: none"> Finite, constant tracking error Limits precision of image field correction at high speeds Typically optimized for a single application Several different tunings necessary, only possible in digital scan systems. | <ul style="list-style-type: none"> No tracking error $t_s = 0$ Precise image field correction even at high speeds Only one tuning needed. Optimum performance across all applications A constant preview time t_p is used to determine the navigable trajectory |
| Use of delays | <ul style="list-style-type: none"> Delays must be determined and set manually Optimization of the delay settings by the user necessary | <ul style="list-style-type: none"> Set by the auto-delay function of the RTC6 |
| Example application: Circles and arcs (circle $v=2.8$ m/s) | <ul style="list-style-type: none"> Necking effects (caused by the tracking error) Adjustment of the circle diameter necessary | <ul style="list-style-type: none"> No necking effects |
| Example application: 90° corners (corner $v=1$m/s) | <ul style="list-style-type: none"> Tracking error can result in a significant corner rounding | <ul style="list-style-type: none"> Significantly smaller deviations during traversal of 90° corners at a wide range of speeds |

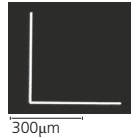
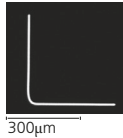
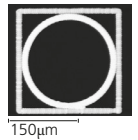
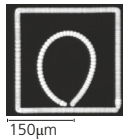

Typical Applications



Micromachining

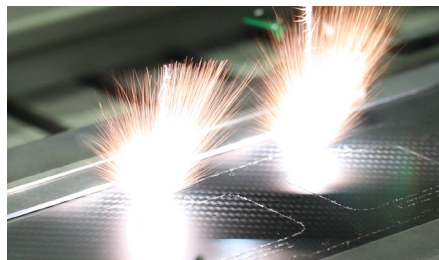

Laser cutting

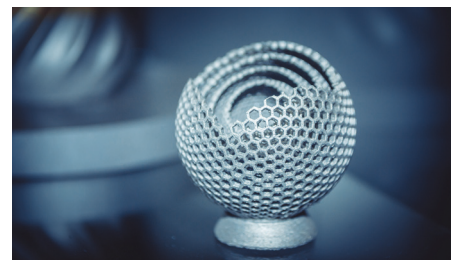

3D printing

General layout (example excelliSCAN 30)

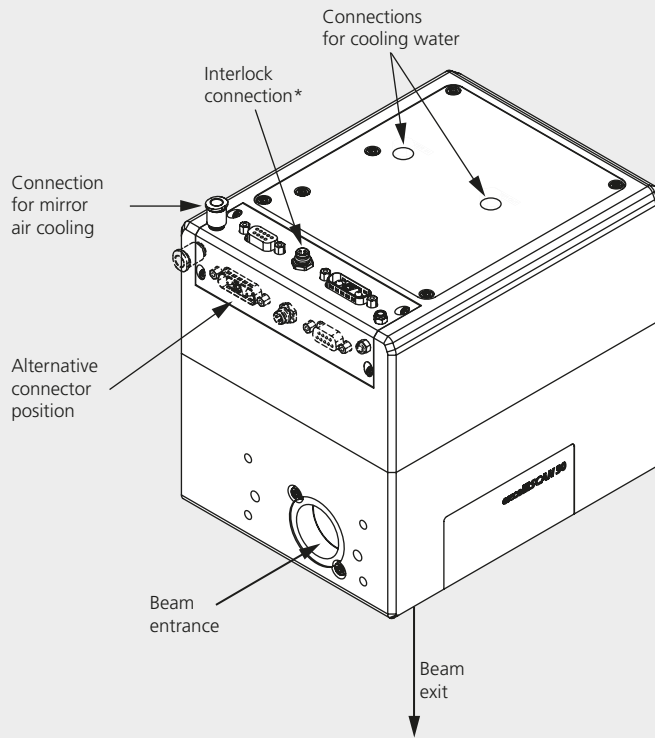

* only excelliSCAN 20 and 30

excelliSCAN 14

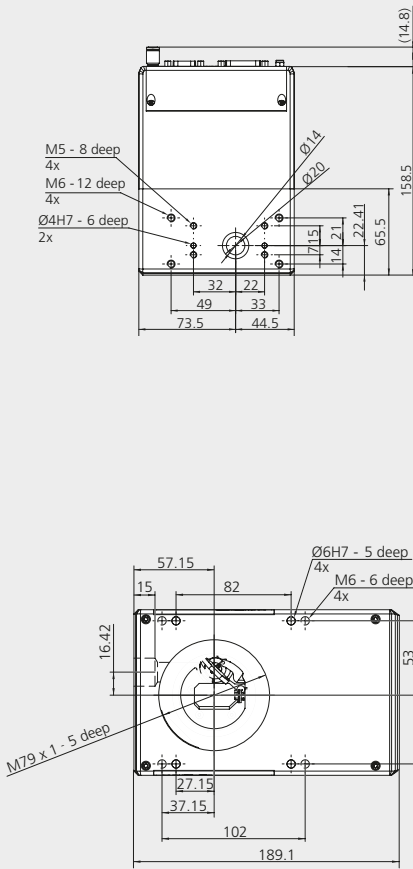

excelliSCAN 20

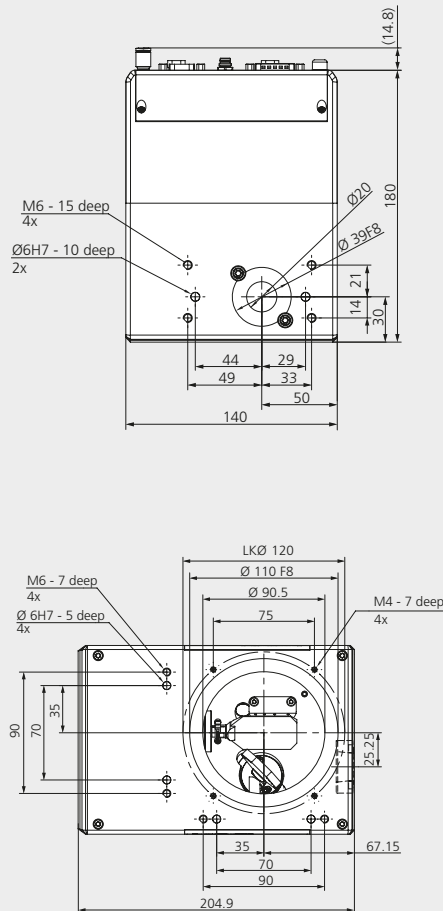

excelliSCAN 30

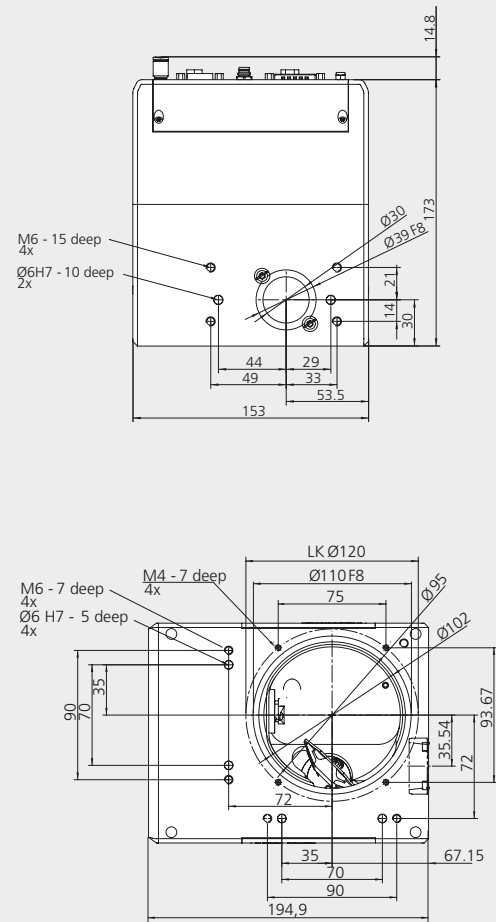

Specifications

Dynamics

| | excelliSCAN 14 | excelliSCAN 20 | excelliSCAN 30 |
|--|-----------------------|-----------------------|-----------------------|
| Aperture [mm] | 14 | 20 | 30 |
| Tuning | universal | universal | universal |
| Tracking error [ms] | 0 | 0 | 0 |
| Typical speeds ⁽¹⁾ | | | |
| Positioning, jump & shoot [m/s] | < 30 | < 16 | < 11.2 |
| Line scan / raster scan [m/s] | < 30 | < 16 | < 11.2 |
| Typical vector marking [m/s] | < 4 | < 2.5 | < 2 |
| Good writing quality [cps] | 1000 | 690 | 590 |
| High writing quality [cps] | 850 | 560 | 460 |
| Positioning times ⁽¹⁾ | | | |
| 1 mm jump width [ms] | 0.28 | 0.40 | 0.44 |
| 10 mm jump width [ms] | 0.88 | 1.25 | 1.43 |
| 100 mm jump width [ms] | 3.70 | 6.88 | 9.47 |
| Acceleration [m/s ²] ⁽¹⁾ | 51 200 ⁽²⁾ | 25 600 ⁽³⁾ | 20 800 ⁽⁴⁾ |

⁽¹⁾ with F-Theta objective, f = 160 mm

⁽²⁾ this corresponds to an angular acceleration of $3.2 \cdot 10^5 \text{ rad/s}^2$

⁽³⁾ this corresponds to an angular acceleration of $1.6 \cdot 10^5 \text{ rad/s}^2$

⁽⁴⁾ this corresponds to an angular acceleration of $1.3 \cdot 10^5 \text{ rad/s}^2$

Further Specifications

| | excelliSCAN 14 | excelliSCAN 20 | excelliSCAN 30 |
|---|-------------------|--------------------------|--------------------------|
| Optical performance ⁽⁵⁾ | | | |
| Typical scan angle [rad] | ± 0.35 | ± 0.35 | ± 0.37 |
| Gain error [mrad] | < 5 | < 5 | < 5 |
| Zero offset [mrad] | < 5 | < 5 | < 5 |
| Power requirements | 30 V DC, max. 3 A | 48 V DC, max. 5 A | 48 V DC, max. 5 A |
| Interface | SL2-100 | SL2-100 | SL2-100 |
| Protective functions | - | Interlock safety circuit | Interlock safety circuit |
| IP code | IP 66 | IP 66 | IP 66 |
| Operating temperature [°C] | 25 ± 10 | 25 ± 10 | 25 ± 10 |
| Weight [kg] | approx. 7 | approx. 10 | approx. 10 |

⁽⁵⁾ all angles are in optical degrees

Precision & Stability

| | excelliSCAN 14 | excelliSCAN 20 | excelliSCAN 30 |
|--|----------------|----------------|----------------|
| Repeatability (RMS) [μrad] | < 0.4 | < 0.4 | < 0.4 |
| Positioning resolution [bit] ⁽⁶⁾ | 20 | 20 | 20 |
| Nonlinearity [mrad] ⁽⁷⁾ | < 0.5 | < 0.5 | < 0.5 |
| Long-term drift ^{(8), (9)} | | | |
| 8-h-drift (after 30 min warm-up) | | | |
| Offset [μrad] | < 20 | < 20 | < 25 |
| Gain [ppm] | < 20 | < 20 | < 25 |
| 24-h-drift (after 3 h warm-up) | | | |
| Offset [μrad] | < 20 | < 20 | < 20 |
| Gain [ppm] | < 25 | < 20 | < 25 |
| Temperature drift ⁽⁹⁾ | | | |
| Offset [μrad/K] | < 10 | < 10 | < 10 |
| Gain [ppm/K] | < 4 | < 5 | < 5 |

⁽⁶⁾ based on the full angle range (positioning resolution 0.8 μrad for angle range $\pm 0.408 \text{ rad}$)

⁽⁷⁾ related to 0.77 rad

⁽⁸⁾ at constant ambient temperature and load

⁽⁹⁾ with water cooling

Options & Variants

Optics

- Standard coatings for all common laser systems: YAG & fiber lasers, lasers in the green wavelength range, UV lasers, DUV lasers, CO₂ lasers
- Objectives with different focal lengths available for various image field sizes

Sensorics (only excelliSCAN 20 and 30)

- Mirror temperature sensors
- Temperature sensor in galvanometer mount

Control Boards/Software

- RTC6 (PCIe und Ethernet) with SCANahead option
- SCANmotionControl
- laserDESK: professional software for laser marking and material processing
- Flexible calibration solutions: CalibrationLibrary, 3D Calibration Wizard (included in laserDESK)

Extensions

- 3D processing in combination with an excelliSHIFT (only excelliSCAN 14) or a varioSCAN II
- Camera adapter for process monitoring

SCANcalc App



Google Play iTunes

